



# Tm Type Modular Low Level Support Structure

*Installation & Users  
Manual*



**Manufactured in the UK**

<b>INTRODUCTION</b> .....	<b>3</b>
<b>HEALTH &amp; SAFETY</b> .....	<b>4</b>
STRUCTURE ASSEMBLY .....	4
ELECTRICAL INTERCONNECTION .....	4
<b>INSTALLATION SEQUENCE</b> .....	<b>4</b>
PART IDENTIFICATION .....	4
WHAT'S INVOLVED ? .....	4
<b>ASSEMBLY OF SUB ARRAYS</b> .....	<b>6</b>
ASSEMBLY OF THE 2 MODULE STRUCTURE .....	6
MODULE PREPARATION.....	6
SUB ARRAY TUBE PREPARATION .....	6
SUB ARRAY ASSEMBLY.....	7
<b>ASSEMBLY OF SUPPORT LEGS TO THE SUB ARRAY</b> .....	<b>8</b>
FRONT LEGS .....	8
REAR LEGS .....	8
SLIDE CLAMPS.....	8
REAR STRUTS .....	8
BASE SWIVEL .....	8
STRUCTURE PLACEMENT.....	9
INSTALLATION OF THE ARRAY ONTO A BOLTED FOUNDATION. ....	9
INSTALLATION OF THE ARRAY ONTO GROUND POLES. ....	10
ADDING ADDITIONAL MODULES .....	11
EARTHING .....	11
<b>PARTS LISTS</b> .....	<b>12</b>
<b>LAYOUT DRAWINGS</b> .....	<b>13</b>
<b>COMMISSIONING TESTS</b> .....	<b>15</b>
SUPPORT STRUCTURE.....	15
<b>MAINTENANCE</b> .....	<b>15</b>
SOLAR MODULES .....	15
ARRAY STRUCTURE.....	15
SITE.....	15

Recommended tightening torques on the fasteners used on  
T type structures.

M6 module fixings	7.6Nm
or	
M8 module fixings	15.4Nm
Grubscrews	39Nm
M10 Anchor bolts	30Nm

**INTRODUCTION**

This manual provides a basic guide to the assembly of the low level support structure, it is recommended that you read through the manual before attempting to assemble the structure taking note of the health & safety issues detailed. The structures are supplied in kits starting with a 2 module structure to which additional extensions are then added to provide the required array size as detailed below:-

Foundation Type	Number of Modules	2 Module Array	2 Module extension	Leg set foundation kit	Leg set ground poles
		001 051	001 055	001 056	001 057
2	1			2	
3	1	1		3	
4	1	1	1	3	
5	1	1	2	4	
6	1	1	2	4	
7	1	1	3	5	
8	1	1	3	5	
9	1	1	4	6	
10	1	1	4	6	
11	1	1	5	7	
12	1	1	5	7	

Ground poles- non foundation	Number of Modules	2 Module Array	2 Module extension	Leg set foundation kit	Leg set ground poles
		001 051	001 055	001 056	001 057
2	1				2
3	1	1	1		3
4	1	1	1		3
5	1	1	2		4
6	1	1	2		4
7	1	1	3		5
8	1	1	3		5
9	1	1	4		6
10	1	1	4		6
11	1	1	5		7
12	1	1	5		7

---

**HEALTH & SAFETY****Structure Assembly**

Construction must not be attempted in high winds. Care must be taken in lifting large solar panels.

Some of the structural components may have sharp edges, take extra care when handling.

When using ground poles, please ensure that the area of installation is free from underground pipework and cabling.

**Electrical Interconnection**

Potentially lethal voltages can be developed from arrays. Take the following precautions:

Electrically isolate the array from the rest of the system.

The modules should be shaded from the sun by opaque sheeting before any electrical connections are made to the sub-array junction boxes or at the control unit.

**WARNING- DO NOT PUT YOUR FINGERS IN THE ENDS OF THE STEEL TUBES, SHARP EDGES**

---

**INSTALLATION SEQUENCE****Part Identification**

Refer to the drawings, photographs and parts list within this manual to familiarise yourself with the components of this structure prior to attempting assembly.

**What's Involved?**

Concrete foundations may be required for this structure, A basic guide to foundations is shown in this manual, but it is suggested that you consult a local civil engineer to establish local ground conditions. Foundations (supplied by others) are to be left to settle for a period of 28 days prior to the installation of the structures.

Preparation of tools, and checking that all components are present.

Assembly of the first 2 module structure

Fitting additional extensions to the structure to establish the required array size.

Compass	To ensure correct orientation
Tape measure (5 metres long)	Measure out mounting points etc.
Post hammer	To insert the ground tubes (if required)
Hammer drill	To drill the footings
10mm masonry bits	To drill the footings
Hammer	To tap in the ground anchor bolts
Allen key (1/4") (SUPPLIED)	General structure assembly
Chalk/felt marking pen	Mark out correct mounting positions
10mm / 13mm A/F spanners	Module mounting bolts
Zinc touch up paint and brush (Galvafruid)	For touching up transit damage
17mm A/F spanners	M10 fasteners and ground anchor bolts
Sponge, cloth and clean water	For cleaning the modules
Opaque sheeting	To shade the modules as required
Inclinometer (angle setter)	To ensure the correct tilt angle is set

*Recommended tools for structure assembly.*



*Right angle clamp*



*End cap*



*Ground anchor bolt*



*Short tee clamp*



*Swivel base clamp*



*Slide clamp*



*Module clamp*



*Internal joiner*



*External joiner*

***Note, the side clamps may be supplied in 2 parts, to be bolted together with the M10 galvanised steel fasteners supplied. Once the structure is fully assembled, these M10 fasteners must be tightened to a torque of 35-40Nm.***

---

## ASSEMBLY OF SUB ARRAYS

### Assembly of the 2 module structure

The first stage is to assemble the first 2 module structure kit, the following describes a suggested method for assembly, as this is a 2 module structure it is easier to assemble this with the modules face down then turn the whole assembly over once complete. We will assume that the structure required is for more than 2 modules and that the first 2 modules are the two on the left when facing the front of the array. If the final structure is a 2 module structure then the only difference is that the array poles can be fitted centrally.

### Module Preparation

Lay the solar modules face down on a smooth flat surface that will not damage the glass, leaving a 10mm gap (approx.) between the two panels. Ensure all the module junction boxes are grouped together on one side. Note - it is important to protect the back of the modules during assembly, use sheets of cardboard so that any smaller components dropped on the back of the module do not damage the module backing material.

### Sub Array Tube Preparation

Locate the sub-array tubes. They can be identified by measuring their length and comparing them with the values in the parts list at the back of this manual. To ensure that you are able to obtain a full tilt angle range, it is important to fit the module clamps onto the sub-array rails correctly. First measure the distance between centres of the mounting holes on the rear of the solar panels as shown below:

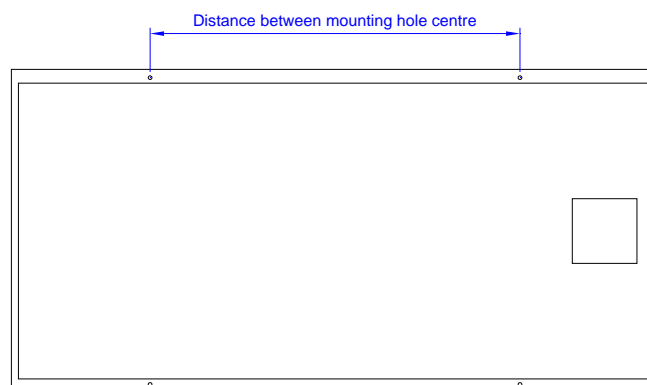

If the distance between the mounting hole centres is 100cm or less then the module clamps must be fitted so that they point outwards towards the ends of the modules.

If the distance between the mounting hole centres is more than 100cm then the module clamps must be fitted so that they point inwards towards the centre of the modules.

For the purpose of this manual we will assume that the hole centres is greater than 100cm

**Upper Sub array Tube** - Slide the Tee clamps and module clamps onto one length of tube. The upper tube is fitted to the junction box end of the modules. Position the clamps so as to line up with the mounting holes on the modules taking note of the above with regard to orientation of the module clamps.

**Lower Sub Array Tube** - Slide the right angle clamps and module clamps onto one length of tube. The upper tube is fitted to the junction box end of the modules. Position the clamps so as to line up with the mounting holes on the modules taking note of the above with regard to orientation of the module clamps.

**Note** - Only tighten the clamps sufficiently to stop them sliding on the tube, they will need to be adjusted when the support legs are fitted later.

**Sub Array Assembly**

Lay the tube assemblies on to the back of the solar modules as shown and position the module clamps so as to line up with the module mounting holes.

Using the M6/M8 fastener kits, bolt the module clamps onto the modules as shown below (we have assumed M8 in the drawing).

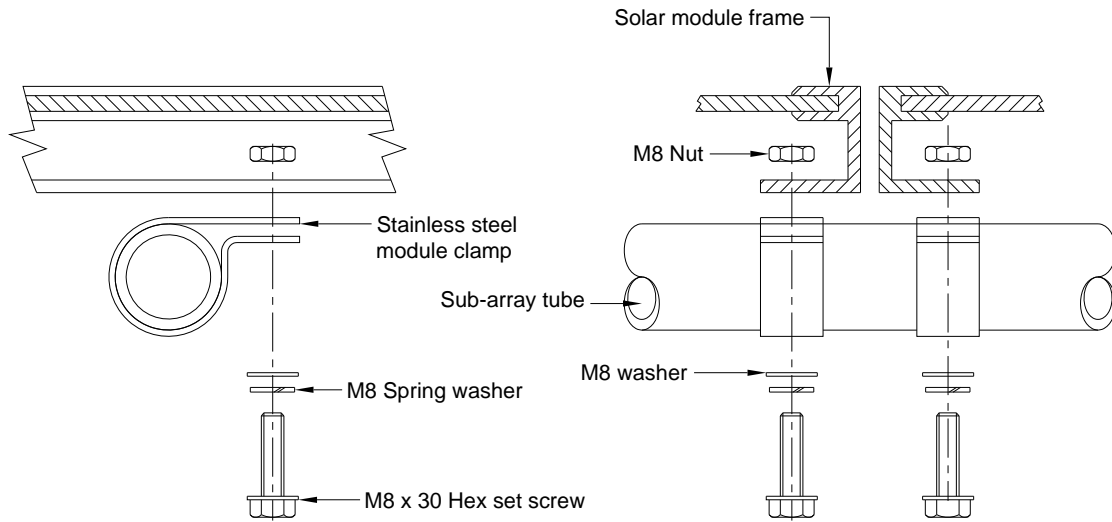

*Module fixing details (Alternative M6 fasteners supplied for some modules).*

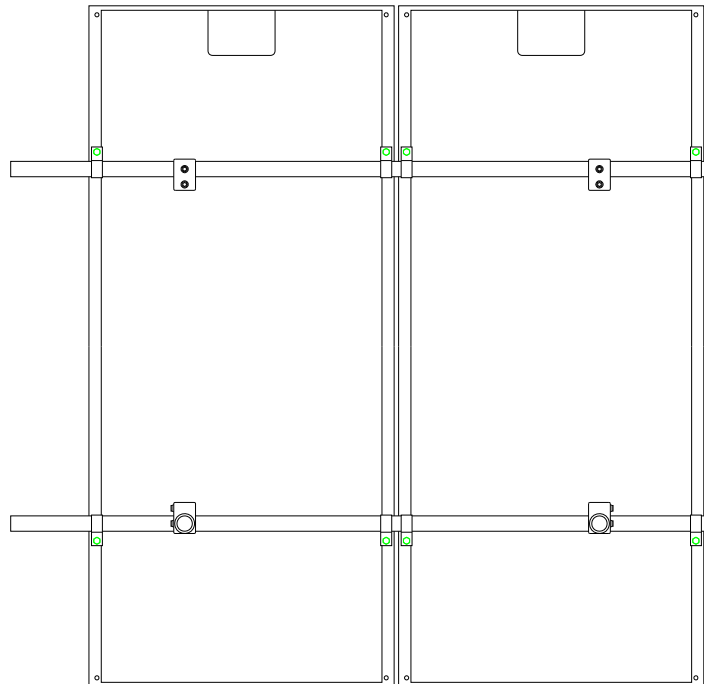

*2 module sub-array assembly with off-set array tubes to allow for extensions to be added*

### Assembly of the support legs to the sub-array

Ensure that the Tee clamps on the back of the array are in the correct position as shown in the detailed drawing at the back of this manual. Their separation must correspond to the separation of the foundation points for the structure. The position of the clamps are easily adjusted by loosening the grub screw using the Allen key supplied, moving the clamp and then re-tightening the grub screw.

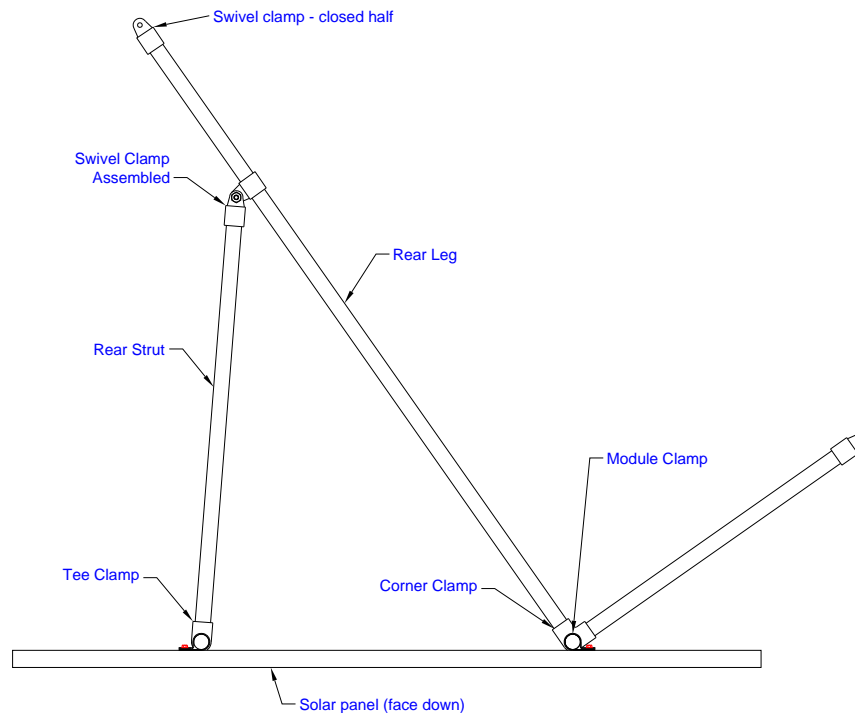

Figure 6.1 : T structure final assembly.

#### Front legs – 720mm

Fit the front legs into each of the right angle clamps on the lower sub array tube. Tighten the grub screws using the Allen key to secure the tubes.

#### Rear legs – 1630mm

Fit the rear legs into the right angle clamps on the lower sub array tube. Tighten the grub screws using the Allen key to secure the tubes.

#### Slide Clamps

Now add the slide clamps to the rear legs and set to approximate tilt angle required, the tilt angle must be checked when in position. Note this clamp may be supplied in 2 parts and bolted together using the M10 fasteners provided.

#### Rear Struts – 1040mm

Insert each rear strut between the slide clamp and the corresponding tee clamp on the upper sub array tube. Tighten the grub screws using the Allen key to secure the tubes.

#### Base swivel

On the end of each leg fit the closed half of the swivel clamp and tighten into place.



**Structure placement**

The assembled array can now be turned over and placed carefully on its feet, If the structure is to be used with concrete foundation then attach a footplate to swivel clamp halves on the bottom of each leg prior to turning the structure over. With the Non-foundation version the open half of the swivel clamp will be pre-fitted onto the ground anchor tubes that have been positioned into the ground as shown later in the manual.

**Installation of the Array onto a Bolted Foundation. (Foundation type only)**

The array must be secured to foundations.

Anchor bolts (expanding) are fitted as illustrated below. It is best to drill and fit only one anchor bolt in each foot (preferably the one that will be difficult to get at when the assembly is finally positioned). Drill the holes 95mm deep with a 10mm masonry bit.

Place the sub array in position and mark out the other holes.

Remove the sub array, drill the remaining holes and fit the anchor bolts.

Replace the sub array over the anchor bolts and fix down.

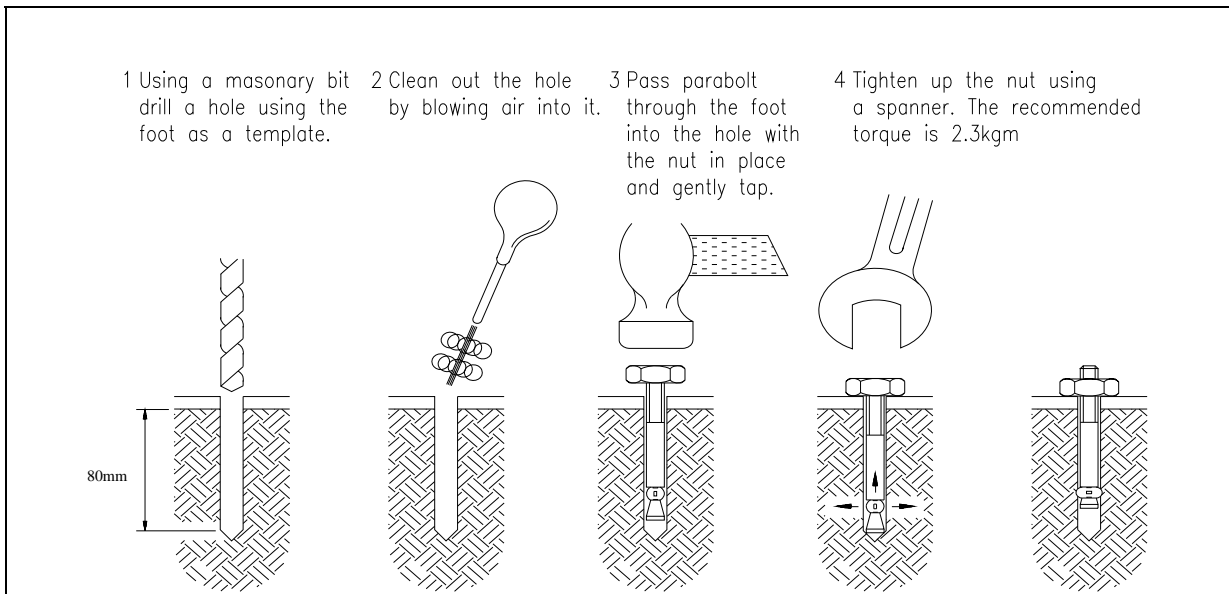
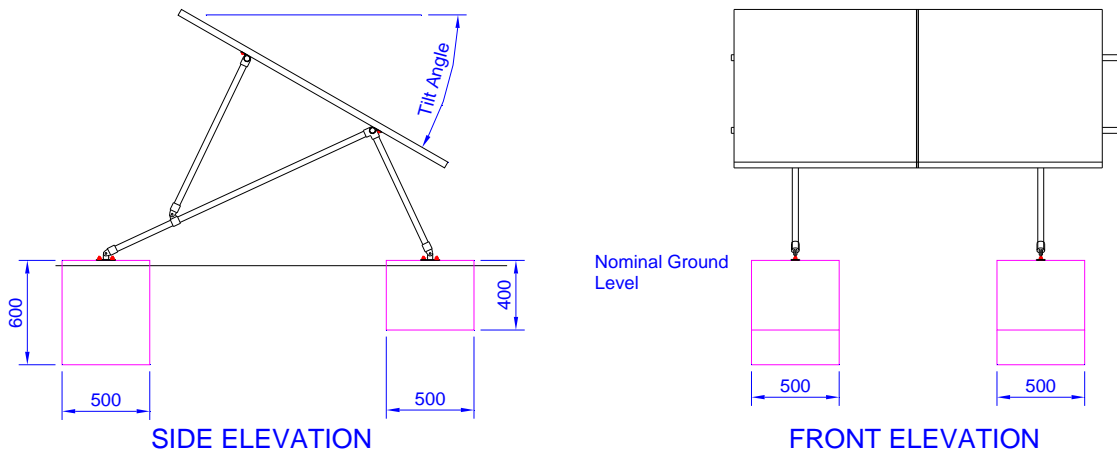

*Fixing of Anchor bolts.*

**Installation of the Array onto ground poles.**

If your structure is supplied with ground anchor poles, you will need to follow these instructions for the final placement of the structure. NOTE longer ground poles may be required for soft grounds, please ensure the ground surface is suitable, if in doubt please consult a local civil engineer.

1. Your kit will consist of 2 part swivel combination clamps c/w M10 fasteners to secure, these are to be fitted onto the ends of each leg so that the clamps swivel front to back.
2. Install the 4 ground poles as shown on the structure drawing, making sure that they are positioned correctly, the distance front to back (north/south) is more critical than the distance sideways (east/West). The installation of the ground tubes will depend upon the ground conditions, a mechanical post knocker is recommended for this.
3. If the top of the tube is damaged during installation, cut the top off with an angle grinder or Hacksaw and paint end with zinc rich paint.
4. Making sure the grub screws in the swivel combination clamps allow the tubes to pass through the clamps, position the structure onto the four ground poles.
5. Lift the structure to just above the ground level and tighten the grub screws.
6. Fit a plastic end cap onto the top of each ground tube.

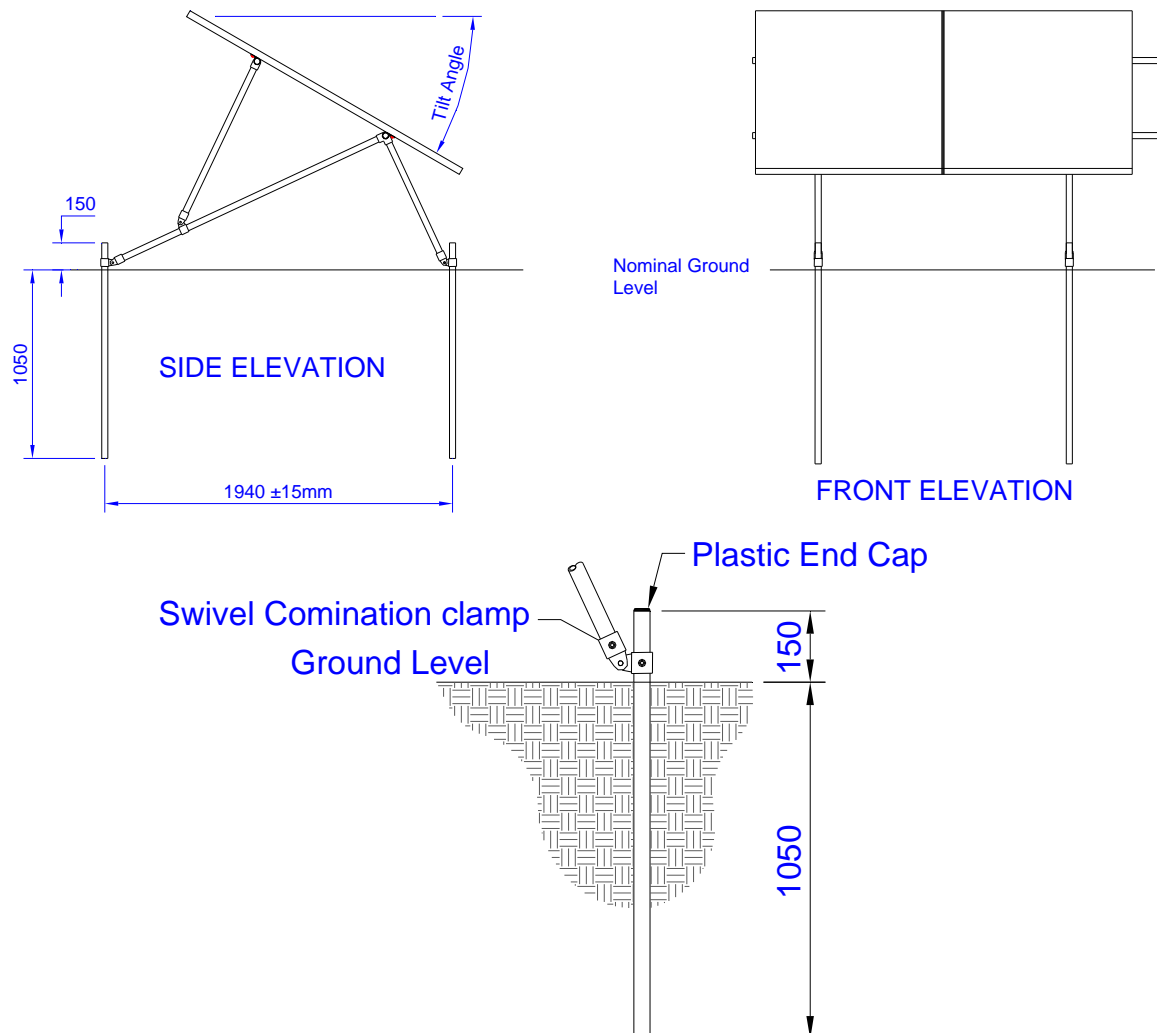

**1050mm minimum to be below ground level on all ground poles, if you surface is uneven then longer poles could be required.**

**Adding additional modules**

The modular T type structure allows you to add additional modules up to a maximum of 12 modules per structure, should you require more than 12 modules then it is advised to start a new array either alongside the original one or behind making sure you allow enough distance to prevent shadowing. Additional 2 module sub-arrays can be easily fitted to the end of the off-set array tubes using the pole joiners as shown below:- If an odd number of modules is required I.E. 3, 5, 7 Etc. then the final array tubes can be cut down to suit ensuring that a minimum of 20mm of tube is present beyond the module. See the typical layouts at the end of the manual.

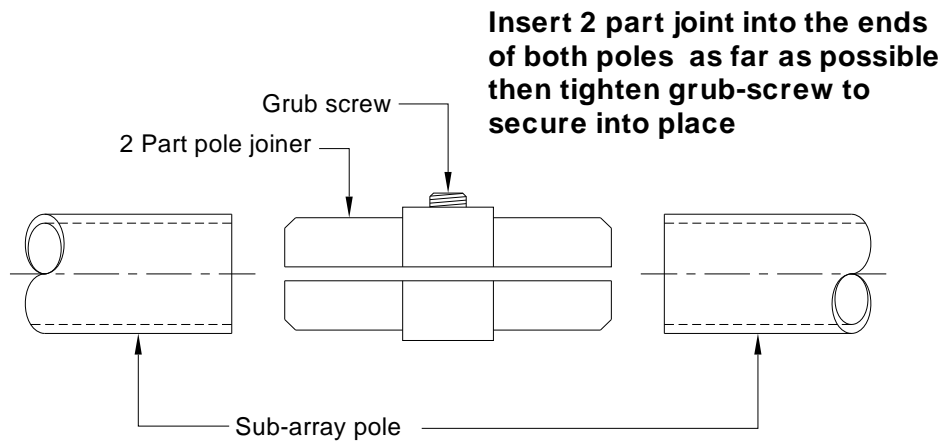

**Fit An External joiner over the internal joiner**

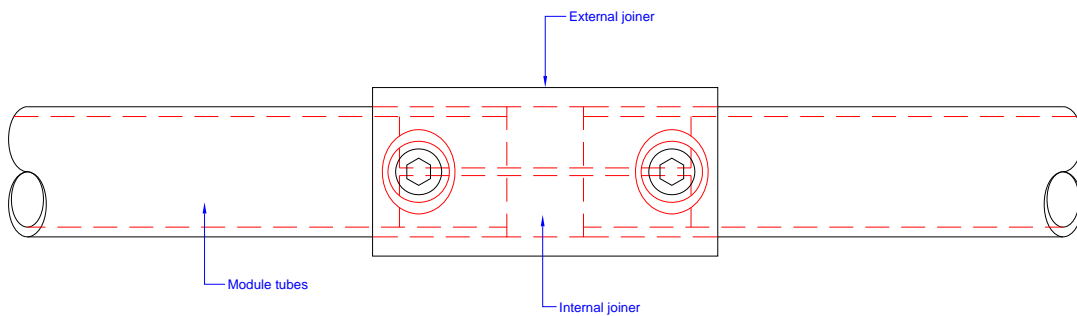

*Pole joint details, larger module kits only*

**Earthing**

The module frames are earthed to one another through the stainless steel module clamps and the structure tubes.

When the structure assembly is completed the array structure should be earthed to ground using a suitable earth. Use earth rods as required.

## Parts list

Modular T type structures		2 Module Array	2 Module extension	Leg set foundation kit	Leg set ground poles
Components	Length	001 051	001 055	001 056	001 057
		QTY	QTY	QTY	QTY
Front leg	720	2	1		
Rear leg	1630	2	1		
Rear strut	1040	2	1		
2 Module array poles	2200	2			
2 Module extension	2105		2		
Ground pole	1200				2
101-2 Short tee		2	1		
116-2 Corner		2	1		
173F-2 Swivel female		6	3		
173M-2 Swivel male		2	1		2
169M-2 foot				2	
150-2 internal joiner			2		
149-2 external joiner			2		
Plastic end cap		4	2		2
Allen key		1			
Module clamp		8	8		
M6 x 25 hex set screw		10	8		
M6 Form C washer		20	16		
M6 Nyloc Nut		10	8		
M8 x 30 hex set screw		10	8		
M8 washer		20	16		
M8 Nyloc Nut		10	8		
M10x40 hex set screw Galv		8	3		
M10 washer Galv		16	6		
M10 spring washer galv		8	3		
M10 Nut galv		8	3		
M10 x 90 through bolt				4	

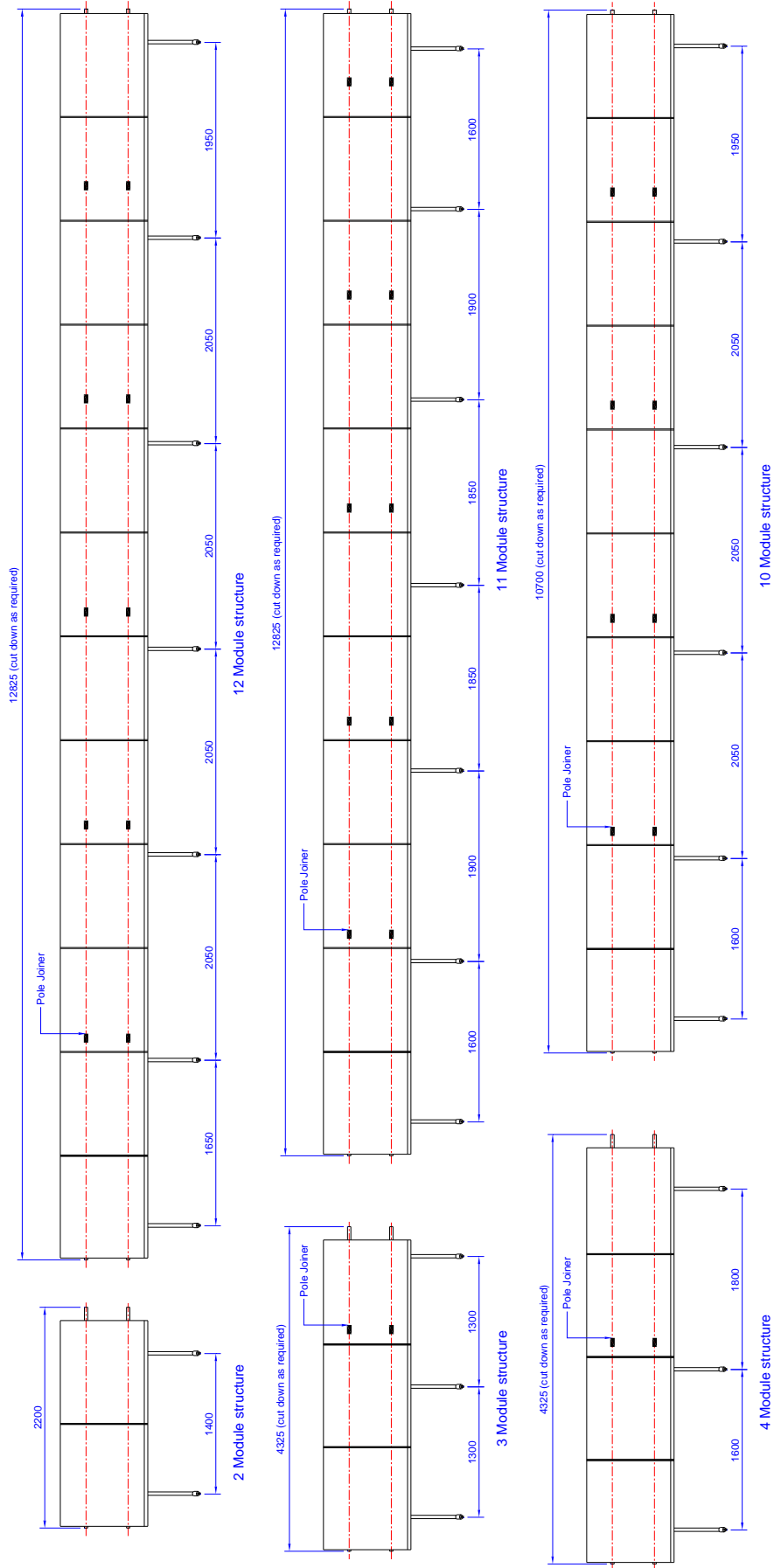

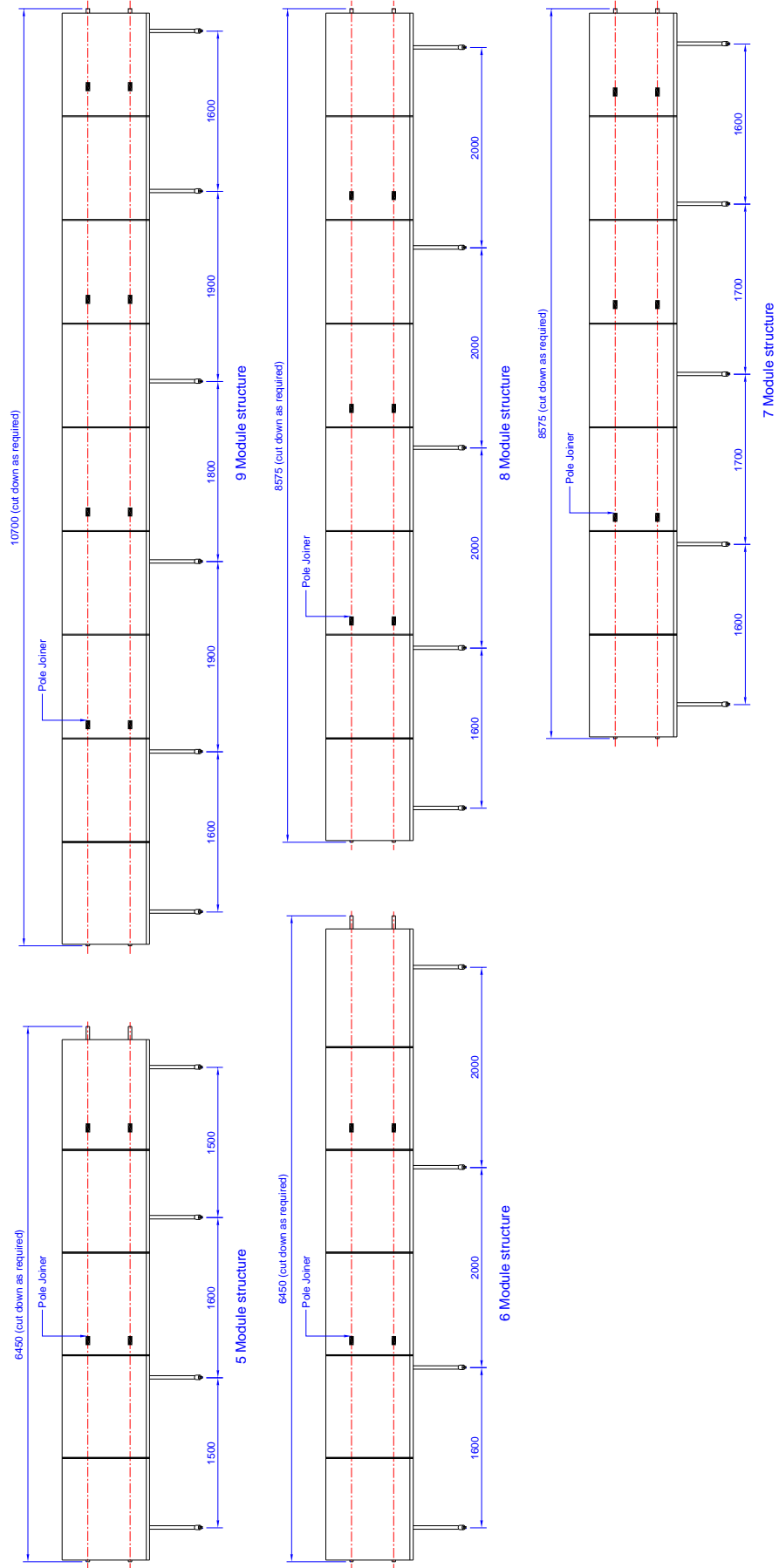

---

**COMMISSIONING TESTS**

In order to ensure that the system has been properly installed and will function correctly, the following tests should be performed immediately after installation.

**Support Structure**

Check module fasteners are tight.

Check all structure fasteners are tight.

Check tilt angle is correct to within  $\pm 2^\circ$

Ensure array is within  $\pm 5^\circ$  of the azimuth specified.

Inspect for any damage to the galvanised steel work; touch up with Galvafruid (or similar) zinc paint as required.

---

**MAINTENANCE**

The following maintenance schedule should be followed at 12 monthly intervals. However, in some areas prone to excessive dust or bird deposits, module cleaning could be necessary more frequently and can only be determined taking local conditions into account.

**Solar Modules**

Check that modules are clean; wash down glass and frames with water. Do not use detergents or solvents.

Inspect modules for damage; ensure glass is undamaged, and that there are no tears in plastic on back of modules.

Inspect module junction boxes; check seal is in place.

**Array Structure**

Inspect for rusting; brush off any rust. Paint affected area with zinc paint.

Ensure all nuts and bolts are tight.

**Site**

Ensure that arrays are not shadowed by growing vegetation; trim vegetation as necessary.

All Tm type structures are available through UK distributors and are manufactured by.

**BDS**

**Unit 8 Alexander House, Thame road  
Haddenham, Buckinghamshire. HP17 8BY UK**