

PROSTAR

SOLAR CONTROLLERS

OPERATOR'S MANUAL

PROSTAR VERSIONS INCLUDED IN THIS MANUAL

	PS-15	PS-30	PS-15M-48V
Rated Solar Current	15A	30A	15A
Rated Load Current	15A	30A	15A
Max. Solar Input Voltage	30/60V	30/60V	120V
System Voltage	12/24V	12/24V	48V
Digital Meter Option	yes	yes	standard
Positive Ground Option	no	yes	yes

8 Pheasant Run
Newtown, PA 18940 USA
phone: 215 321 4457
fax: 215 321 4458
email: info@morningstarcorp.com

PROSTAR DIMENSIONS

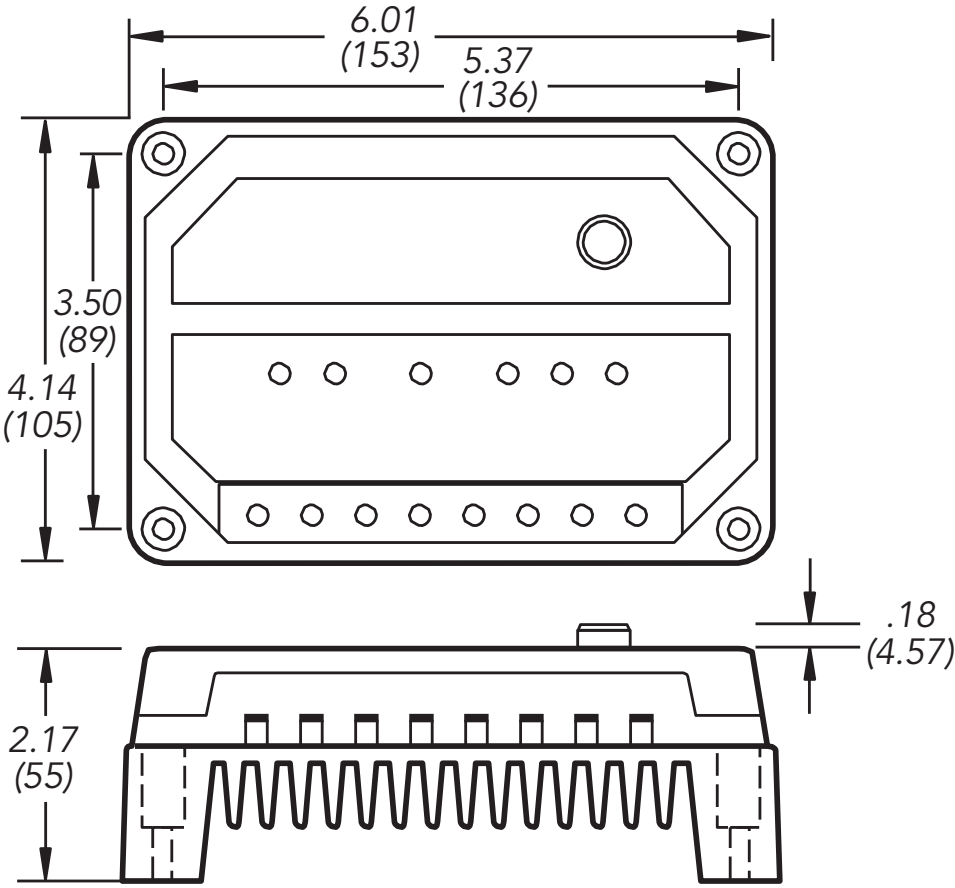

inches (mm)

CONTENTS

1.0 GENERAL INFORMATION	4
2.0 IMPORTANT SAFETY INFORMATION	4
3.0 QUICK START INSTRUCTIONS	4
4.0 LED INDICATORS	5
5.0 DIGITAL METER & MANUAL DISCONNECT	6
5.1 Digital Meter	6
5.2 Manual Disconnect	6
5.3 Display Disconnects & Protections	6
5.4 Self-Diagnostics (Self-Test)	6
6.0 INSTALLATION INSTRUCTIONS	8
6.1 General Installation Notes	8
6.2 Installation Steps	8
7.0 OPERATION	10
7.1 Operator's Tasks	10
7.2 Operations & Functions	11
7.3 Protections	11
7.4 Inspection & Maintenance	12
7.5 Special Features	12
8.0 BATTERY CHARGING INFORMATION	13
8.1 ProStar Charging Method	13
8.2 Select Battery Type	13
8.3 ProStar Charging Features	13
9.0 TESTING AND TROUBLESHOOTING	14
9.1 Self-Diagnostics	14
9.2 Technical Support	14
9.3 Testing with a Power Supply	14
9.4 Troubleshooting	15
10.0 SPECIFICATIONS	17

1.0 GENERAL INFORMATION

Thank you for selecting the ProStar solar controller. This second generation ProStar adds new features and protections using highly advanced technology. Morningstar's patented PWM battery charging algorithm has also been further optimized for longer battery life and improved system performance.

Many functions of the ProStar are unique. Although the ProStar is very simple to use, please take the time to read this operator's manual and become familiar with the controller. This will help you to make full use of the many advantages the ProStar can provide for your solar system.

2.0 IMPORTANT SAFETY INFORMATION

"Always Put Safety First"

- Be very careful when working with batteries. Wear eye protection. Have fresh water available to wash and clean any contact with battery acid.
- Charge only lead-acid batteries that are properly sized for the system.
- Explosive battery gasses can be present during charging. Be certain there is enough ventilation to release the gasses.
- Use insulated tools and avoid metal objects near the batteries.
- Carefully read the battery manuals and other equipment manuals before installing the solar system. Observe ALL precautions when working with batteries and power electronics.
- Fuses or DC disconnects may be required in the system. These protective devices are not part of the ProStar controller.
- Avoid large voltage drops in the battery wires. Use the Battery Sense connection for best battery charging and system performance.
- Do not allow water to enter the controller.
- Avoid touching the controller heat sink. Under certain operating conditions, the heat sink can become hot.
- Install the controller in a vertical position with adequate space for ventilation.
- Ensure that the system is properly grounded.
- SAVE these instructions for future reference.

3.0 QUICK START INSTRUCTIONS

This section provides a brief overview of how to get started using the ProStar controller. However, please review the entire manual to ensure best performance and years of trouble-free service.

1. Verify that the nominal array voltage matches the nominal battery voltage.
2. Verify that the solar and load currents will not exceed the ratings of the ProStar version being installed.
3. Verify that the solar input voltage (temperature compensated Voc) will not exceed the rating for the applicable system voltage

4. Mount the ProStar to a vertical surface. Allow space above and below the controller for air flow. The heat sink MUST be in a vertical (up & down) position.
3. Connect the Battery first. Observe that the Battery Status LEDs blink in sequence one time. Torque all the ProStar terminals tightly, but do not exceed 35 in-lb.
4. Connect the battery Sense. This is recommended, but not required, if the battery is located more than 5 meters from the controller.
5. Connect the **Solar**. With sunlight, the green Charging LED will light.
6. Connect the Load. If there is a fault, the LEDs will begin blinking. Refer to section 4.0 of this manual to identify the fault.

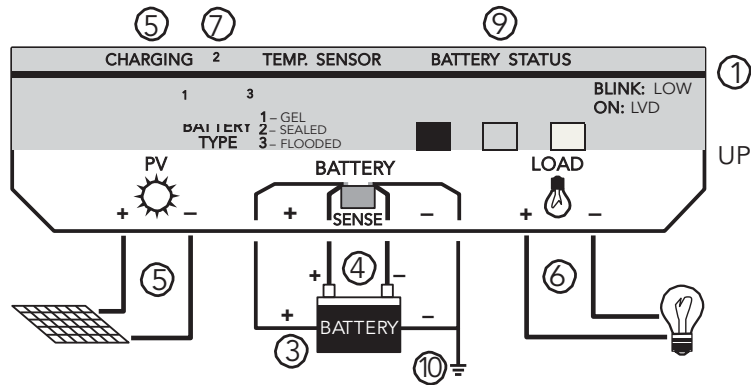

7. Select the proper charging for the battery being used. Turn the rotary switch with a screwdriver to the Battery Type printed on the label. The Battery Status LEDs will blink 1, 2 or 3 times depending on the Battery Type selected.
8. For 12 or 24 volt systems, the ProStar will automatically select the system voltage. If the system is 24 volts, first confirm that the battery is above 15.5 volts. The controller selects 12 or 24 volts at start-up.
9. Observe the LEDs and digital meter (if provided) to confirm normal operation.
10. It is recommended that the system be properly grounded.

4.0 LED INDICATORS

The 4 LEDs in the lower label indicate system status and various faults. These functions are described below.

CHARGING (LED 1 – green)

- ON: battery charging during sunlight (always on during sunlight)
- OFF: normal during night (off during sunlight indicates solar reverse polarity or overcurrent)

BATTERY STATUS (LEDs 2 – 4)

- GREEN: ON indicates battery is near full charge
BLINKING indicates PWM charging (regulation)
- YELLOW: ON indicates battery at middle capacity
- RED: BLINKING indicates a low charge state and low voltage disconnect (LVD) warning ; SOLID indicates that the load has been disconnected (LVD)

FAULT INDICATIONS (G = green; Y = yellow; R = red)

G/Y/R blinking together	– battery select fault
R – Y sequencing	– high temperature disconnect
R – G sequencing	– high voltage disconnect
R/G – Y sequencing	– load short circuit or overload

5.0 DIGITAL METER & MANUAL DISCONNECT

A digital meter is available with the ProStar controller as an option. If your version includes the meter display, this section will describe the information that can be displayed with the meter, and the added capabilities that are enabled by the push button switch.

5.1 DIGITAL METER

A precision 3-digit digital meter will continuously display battery voltage, solar current, and the load current. The meter automatically scrolls through these 3 displays. The 3 red LEDs will indicate which parameter is being displayed.

The digital meter will operate from -30°C to $+85^{\circ}\text{C}$. The values displayed are calibrated electronically in production and are accurate to within a few percent. Please note, however, that if the Battery Sense is not connected, the voltage displayed will be in error by the voltage drops in the battery wires.

5.2 MANUAL DISCONNECT

The push button next to the digital display can disconnect the Load or both Load and Solar. A second push of the button will return the controller back to normal operation.

LOAD OFF: A brief push of the button (less than 2 seconds) will disconnect the Load. The Solar remains on and charging.

LOAD AND SOLAR OFF: If the button is held down for 2 seconds, the Solar will also be disconnected.

When the button is pushed, the red LED inside the cap will light. In addition, the Load or both Load and Solar will display "OFF" in the digital meter to indicate the disconnected state.

5.3 DISPLAY DISCONNECTS & PROTECTIONS

The following protection functions and disconnect conditions will be displayed in the digital meter when they occur:

<i>Lvd</i>	LVD – low voltage load disconnect (load only)
<i>Hvd</i>	high voltage disconnect (both solar and load)
<i>Hot</i>	high temperature disconnect (both solar and load)
<i>OCP</i>	overcurrent and short circuit protection (load, solar overcurrent)
<i>0.0</i>	short circuit protection (solar only)

5.4 SELF-DIAGNOSTICS (SELF-TEST)

If the push button is held down for 4 seconds, the ProStar will go into automatic self-diagnostics. Note that the button must be released to start the self-test.

NOTE: The push button can be used to toggle through the displays faster. The entire self-test takes 30 to 45 seconds. The load will be turned on for 0.1 second and may flash during the test. A short or overload condition could cause a controller restart.

The following displays will occur (examples are used):

<i>B.B.B</i>	self-test started, checking the digital meter segments
<i>12u</i>	the system voltage (12/24/48)
<i>15A</i>	ProStar current rating
<i>r 1.5</i>	software version installed
<i>E04</i>	a fault has been detected (see list below)
<i>---</i>	display if no fault is found
<i>25c</i>	temperature measured at the controller remote
<i>rP</i>	temp probe is detected (if connected)
<i>25c</i>	temperature at the remote probe (if connected)
<i>SEn</i>	battery sense detected (if connected)
<i>S-1</i>	battery select position (1,2, or 3)
<i>J-1</i>	telecom noise jumper cut (change to on-off regulation)
<i>End</i>	end of the self-test
<i>End---End</i>	display continues if no error was detected.
<i>End End</i>	display continues if an error has been detected.

To terminate the self-test, push the button.

The self-test can be repeated to confirm the result.

Error List:

E01	Rotary switch battery selection failure
E03	Voltage reference test failed (circuit, malfunctions)
E04	Solar array current fault (circuit, FETs)
E07	Load FETs off test (load connection, FETs shorted)
E08	Load current fault (circuit, FETs)
E09	Load FETs on test (load circuit, FETs open)
EI0	Internal temp sensor out of range high
EI1	Internal temp sensor out of range low
EI2	Remote temp probe out of range
EI3	Battery sense fault (battery V drop over 5V, no Sense negative connection)

NOTE: In addition to the self-test, observe the solar and load currents displayed in the meter. The self-diagnostics plus the currents displayed in the meter will provide a comprehensive test of the ProStar. Some faults may exist that are not detected by the self-test, but the large majority of potential faults will be tested and reported in this self-diagnostic test.

Refer to section 9.0 for more information.

6.0 INSTALLATION INSTRUCTIONS

The ProStar is installed in 10 steps. Follow the procedure in section 6.2 for a proper installation and best performance.

6.1 GENERAL INSTALLATION NOTES

- The ProStar uses stainless steel fasteners, an anodized heat sink, and conformal coating to protect from harsh conditions. However, for acceptable service life extreme temperatures and marine environments should be avoided.
- The ProStar prevents reverse current leakage at night, so a blocking diode is not required in the system.
- The ProStar is designed to regulate ONLY solar (photovoltaic) power. Do not connect it to any other type of power generator. Do not attempt to regulate a wind turbine. However, other power sources can be connected directly to the battery.
- The connector terminals will accept a maximum wire size of AWG #6 / 16 mm² (solid/multistrand) or AWG #8 / 10 mm² (fine strand). Use a flathead insulated screwdriver, and torque tightly up to 35 in-lb.
- Fuses or DC disconnects may be required in the system. These protection devices are not part of the ProStar controller.

NOTE: Carefully observe the LEDs at each connection. The LEDs will indicate proper polarity and a good connection.

6.2 INSTALLATION STEPS

Refer to the wiring connection diagram in section 3.0.

STEP 1: Mounting

Inspect the controller for shipping damage. Mount the ProStar to a vertical surface (4 stainless steel #8 self-tapping screws are included). Tighten the mounting screws using care not to crack the plastic case. Do not install directly over an easily combustible surface since the heat sink may get hot under certain operating conditions.

NOTE: Heat sink must be in a vertical position (fins up and down).

Allow at least 15 cm (6 inches) space above and below the controller for air flow. Install in an area protected from direct rain and direct sun.

If the controller is installed in an enclosure, some ventilation is recommended. Do not locate in an enclosure where battery gasses can accumulate.

STEP 2: Ratings

Confirm that the solar array and loads will not exceed the current rating of the ProStar version being installed.

Multiple ProStar units can be paralleled at the system battery to increase the solar capacity, but do not parallel loads.

NOTE: The battery should be connected first. This will activate the controller protection features, and will power the LEDs to guide installation and start-up.

STEP 3: Battery

Before connecting the battery, measure the battery's open-circuit voltage. It must be over 8 volts to operate the controller. For 24 volt systems, the battery must be over 15.5 volts or the ProStar will regulate for 12V. The 12/24V auto selection is only done at start-up.

Connect the battery and confirm that the 3 Battery Status LEDs blink in sequence. If they do not light, check the battery polarity (+/-) and battery voltage.

CAUTION: The ProStar is protected against all faults EXCEPT a reversed battery connection together with a polarized or short circuited load. CONFIRM that the battery + and - wires are correctly connected before proceeding. Check the wires and the LEDs.

The green, yellow or red LED will light depending on the battery charge state. Confirm one of these LEDs is on before going to the next step.

STEP 4: Sense

Battery sense connections are recommended if the controller is more than 5 meters from the battery. The Sense, connected directly to the battery, will improve the battery charging and control.

Both Sense wires (+/-) must be connected. A small wire size (18 AWG or larger) can be used for the Sense because the current is very low. Note that the middle 2 terminals are for sense (with the smaller wire slots in the case).

NOTE: If the Battery input voltage is more than 5 volts different than the Sense due to voltage drops or faulty connections, the Sense input will not be recognized by the ProStar.

STEP 5: Solar

These terminals are used to connect the Solar (PV) array. First confirm that the solar modules are wired for the same voltage as the battery.

Use caution, since the solar array will produce power whenever in sunlight. If the solar is connected while in sunlight, the Charging LED indicator will light. Confirm proper connection with the Charging LED.

STEP 6: Load

Turn the load off, and connect the load wires to the Load terminals. Turn the load on to confirm a proper connection.

If the load does not turn on, it could be for various reasons:

- the ProStar is in LVD (red LED on)
- there is a short circuit in the load (LEDs blinking R/G – Y)
- there is an overload condition (LEDs blinking R/G – Y)
- the load is not connected, not working, or turned off

Confirm the load is working properly before going to Step 7.

STEP 7: Battery Type Selection

Using a small screwdriver, turn the rotary switch to select the Battery Type. There are 3 choices (see section 8.2):

- 1 = Gel battery
- 2 = Sealed battery
- 3 = Flooded battery

A proper selection will flash the 3 Status LEDs together: 1 time for Gel, 2 times for Sealed, and 3 times for Flooded.

If the rotary switch does not make a good contact with one of the 3 selections, the 3 LEDs will start flashing together and continue until a good contact is made.

STEP 8: Confirm Installation

After the connections are completed, observe the LEDs to make sure the controller is operating normally for system conditions. If the optional digital meter is provided, observe that the display is scrolling with proper voltage and amperage values. A self-test can be performed with the digital meter (see section 5.4).

STEP 9: Grounding

For safety and effective lightning protection, the negative conductor of the solar system should be properly grounded (see the NOTE below). In addition, the heat sink can be grounded with a #8-32 UNC or M4 screw (0.136 hole provided).

The Solar, Battery, and Load negative terminals are all connected together inside the ProStar per UL recommendations. No switching or measurement is done in the negative current path.

NOTE: For positive ground versions, the Solar, Battery and Load POSITIVE terminals are connected together inside the ProStar. The positive system conductor must be properly grounded. Make sure the upper label of the ProStar indicates "Positive Ground" above the version number to confirm this is a positive ground ProStar controller.

7.0 OPERATION

7.1 OPERATOR'S TASKS

The ProStar is a fully automatic solar system controller that includes many electronic functions to protect both the controller and the solar system. Battery charging is also fully automated (see section 8.0).

The only manual tasks performed by the operator are:

- a. Installation (see section 6.2)
- b. Battery type selection (see section 6.2, Step 7)
- c. Disconnect button / Self-test (see section 5.2 and 5.4)
- d. Reset if a load short circuit does not automatically clear (see section 7.3)
- e. Maintenance (see section 7.4)

7.2 OPERATIONS & FUNCTIONS

The solar system operator should become familiar with the following operating functions of the ProStar controller. Refer to the Technical Specifications (section 10.0) for actual setpoints and other parameter values.

- 100% Solid State: All power switching is done with FETs. No mechanical relays are used in the controller.
- Battery Charge Regulation: The ProStar is a PWM battery charger. See the next section (8.0) for a description of battery charging.
- Low Voltage Load Disconnect (LVD): An automatic load disconnect protects the battery from deep discharge. The load automatically reconnects when the battery recovers. A 4-minute delay prevents false LVD disconnects.
- Low Voltage Warning: The red status LED will blink at low battery capacity to warn of a possible LVD.
- Parallel Controllers: ProStar controllers work very well in parallel configurations. No blocking diodes are required. Each controller must have an independent and separate solar subarray and a load that does not exceed the controller's rating.
- Auxiliary Generators: Engine generators and other sources of power may be connected directly to the battery for charging. It is not necessary to disconnect the ProStar from the battery. However, do not use the ProStar to regulate these other sources of power.

Noise: The ProStar circuit minimizes switching noise and filters noise output. A properly grounded system will also minimize noise. If noise is present in a telecom or radio load, refer to section 7.5 below.

7.3 PROTECTIONS

The ProStar is fully protected against system faults listed below. Recovery is automatic except where noted below. Refer to sections 4.0 and 5.0 for fault indications.

- Solar short circuit and overload – fully automatic recovery
- Load short circuit and overload – after 3 automatic load reconnect attempts (10 seconds between each attempt), the fault must be cleared and the load must be turned off or disconnected for 10 seconds or longer to restore power to the load terminals.
- Reverse polarity – fully protected except per Caution below
- Battery disconnected – the load is protected from voltage spikes
- High temperature – first the solar is disconnected, then the load will be disconnected; auto reconnects
- High battery voltage – first the solar is disconnected, then the load will be disconnected; auto reconnects
- Very low battery voltage – brownout protection, auto recovery into LVD state
- Battery select error – defaults to gel battery setting, flashes LEDs
- Temperature sensor failure – a remote probe failure defaults to the internal temperature sensor, which defaults to a fixed 25°C if it fails

CAUTION: One source of potential damage to the controller is a reversed battery polarity (+/-) together with a polarized or short-circuited load.

7.4 INSPECTION & MAINTENANCE

The following inspections and maintenance tasks are recommended at least two times per year for best controller performance.

1. Confirm that the correct battery type is selected. Turn the rotary switch to another setting and then back to the setting desired, and count the LED flashes.
2. Confirm that the maximum current of the solar array and load does not exceed the ProStar ratings.
3. Tighten all the terminals. Inspect for loose or broken wire connections.
4. Check that the controller is securely mounted in a clean, protected environment.
5. Check that the air flow and the ventilation holes are not blocked.
6. Inspect for dirt, insects, nests, and corrosion.
7. Check that the controller functions and LED indicators are correct for the system conditions at that time.

7.5 SPECIAL FEATURES

Two specialized capabilities will apply to some ProStar owners.

A) Remote Temperature Probe

An optional remote temperature probe can be soldered to the ProStar assembly at any time. The standard cable length is 25 ft (7.6 m), and this can easily be extended to 100 ft (30 m) or longer. The 2 probe wires are soldered to the main board assembly between the temperature sensor and the green LED, at "J12".

Instructions are provided with the remote probe. The ProStar will automatically select the remote probe for battery temperature compensation if it is installed.

B) Telecom Noise Jumper

Some telecom equipment will produce noise when the ProStar begins PWM regulation. If this occurs, a jumper can be cut to eliminate the noise. Instructions follow:

- First, try to improve the system grounding which often eliminates the noise. The PWM battery charging provides a significant benefit to the battery, and it is worth trying to preserve the PWM charging.
- If the noise continues, disconnect the controller and remove the ProStar assembly from its plastic case.
- Locate a vertical resistor in the upper right hand corner of the board, near the microcontroller. This is identified as "J11" on the board.
- Cut one leg of the resistor and separate the leads.

This will convert the battery charging to a typical "on-off" regulation of the solar energy. The switching is very slow, so the noise will not be noticeable. The equalization and float features of the battery charging algorithm are preserved in the "on-off" mode.

In the future, this can be reversed back to PWM if the cut jumper leg is soldered back together.

8.0 BATTERY CHARGING INFORMATION

The ProStar is an advanced, fully automatic solar battery charger. No adjustments are required except to select the battery type at installation (see section 8.2 below).

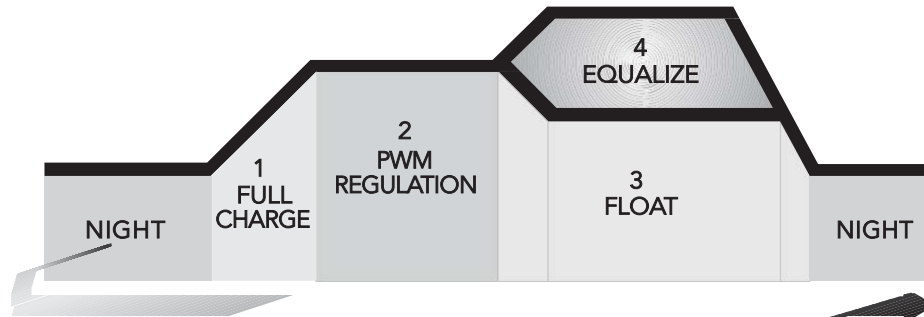

8.1 PROSTAR CHARGING METHOD

The ProStar uses 4 stages of charging for rapid, efficient and safe battery charging. These are shown in the diagram below:

1. Recharging with 100% of available solar energy.
2. PWM constant-voltage regulation to prevent heating and excessive battery gassing. Pulse charging to restore full battery capacity.
3. Float: After battery is fully recharged, ProStar reduces to a float or trickle charge. The transition depends on battery history. A load that exceeds available solar output will return ProStar to the PWM mode.
4. Equalize: A boost charge that depends on elapsed time and battery history. Flooded cells receive a vigorous equalization, sealed batteries a smaller boost to bring uneven cells into balance and extend the battery life. Gel cells are not equalized.

8.2 SELECT BATTERY TYPE

The Battery Type rotary switch allows selection of 1 of 3 charging algorithms. These are broadly defined as the following battery types as noted on the lower label:

1. Gel: Some gel and other battery types recommend lower regulation voltages and no equalization. This setting regulates to 14.0V (for a 12V battery).
2. Sealed: AGM, "maintenance free" and some types of gel batteries. Regulates to 14.15V (12V battery) with 14.35V boost charging.
3. Flooded: Vented cells that require water to be added. Regulates to 14.4V with 14.9V and 15.1V equalizations (12V battery).

The above values are 2 times for 24V, and 4 times for 48V.

The battery type selection can be changed at any time.

8.3 PROSTAR CHARGING FEATURES

Other ProStar capabilities for best battery life follow:

- Night Disconnect: The solar array automatically disconnects at night to prevent reverse current leakage from the battery.

- **Battery Sense:** Good battery performance requires accurate charging. Voltage drops in the battery power cables can distort the battery charging. The Sense wires eliminate the voltage drops for optimized charging.
- **Temperature Compensation:** Four control setpoints (25°C reference) are compensated for temperature (PWM regulation, float, equalization, high voltage disconnect). The charging is compensated by $-5 \text{ mV}/^\circ\text{C}$ /cell ($-30\text{mV}/^\circ\text{C}$ for a 12V battery). Compensation is limited to minus 30°C.
- **Remote Temperature Probe:** An optional probe is available to measure temperature at a location away from the controller. This requires soldering 2 wires to the ProStar PCB. See section 7.5.
- **Battery Equalization:**

	Sealed	Flooded
Calendar – 25 days		
Equalization voltage	14.35	14.9
Cumulative time	1 hour	1 hour
Time starts above (V)	14.3	14.6
Battery History (flooded only)		
Battery voltage falls below (V)	N/A	11.7
Equalize voltage		15.1
Cumulative time		2 hours
Time starts above (V)		14.6
Reset 25-day calendar		yes

The above battery setpoints are 2 times for 24V, and 4 times for 48V.

9.0 TESTING AND TROUBLESHOOTING

9.1 SELF-DIAGNOSTICS

If your ProStar includes the optional digital meter, refer to section 5.4 for how to perform a self-test of the ProStar. This will test for almost all failure modes of the ProStar and display any faults that are found.

If the self-diagnostic test indicates that no failures were found, it is very likely that the problem is with the solar system or battery.

9.2 TECHNICAL SUPPORT

Additional technical information and support can be found at Morningstar's Website:
[**www.morningstarcorp.com**](http://www.morningstarcorp.com)

9.3 TESTING WITH A POWER SUPPLY

The ProStar can be tested with a power supply used in place of either the solar array input or the battery. To avoid damage to the ProStar, observe the following cautions:

- Current limit the power supply to no more than half the ProStar rating.
- Set the power supply to 15 volts DC or less for 12V systems (30V for 24V systems and 60V for 48V systems).
- Connect only one power supply to the controller.

Failure to follow these precautions may void the warranty.

9.4 TROUBLESHOOTING

The ProStar is assembled with automated equipment, tested with computers, and is protected from faults. It is usually worthwhile to troubleshoot the entire solar system for faults, since the ProStar will generally not be the cause of a problem. Most problems will be caused by wiring connections, batteries unable to hold a charge, or faulty loads.

CAUTIONS:

1. Troubleshooting should be done by qualified personnel.
2. A battery can cause serious damage if shorted.
3. There are no user serviceable parts, fuses or circuit breakers inside the ProStar.
4. Observe all normal precautions when working with energized circuitry.

NOTE: If soldering is required, simply solder-through the conformal coating. The coating is acrylic and does not affect soldering.

1. BATTERY IS NOT CHARGING

- Check the green CHARGING LED above the Solar input. With sunlight on the solar array, this LED should be on.
- Check that the proper BATTERY TYPE has been selected.
- Check that all wire connections in the system are correct and tight. Check the polarity (+/-) of the connections.
- Measure the solar array open-circuit voltage (disconnected from the controller) and confirm it is normal. If the array voltage is low or zero, repair the fault in the array.
- Confirm that the load is not drawing more energy than the solar array can provide.
- If the BATTERY SENSE terminals are not used, there may be excessive voltage drops between the ProStar and the battery. This is a common cause of undercharging batteries. See section 6.2 to connect the Battery Sense.
- Check the condition of the battery. Determine if the battery voltage falls at night with no load. If the battery is unable to maintain its voltage, it may be failing
- Measure the solar input voltage (during daytime) and battery voltage at the ProStar terminals. If the voltages at the terminals are the same (within about 0.5 volts), the solar array is charging the battery. If the solar voltage is close to open-circuit (about 20V), and the battery voltage is low, the controller is not charging the battery and may be defective. Make sure the ProStar is not in regulation (PWM) for this test (see section 4.0).

NOTE: If the battery is not being fully recharged, measure the voltage at the battery terminals on the ProStar, and then at the terminals on the battery. This should be done at midday with full charging from the solar array (and not in PWM regulation). If the ProStar terminals are 1 volt higher than the battery terminals, for example, this voltage drop will cause the battery to regulate 1 volt below its desired regulation (PWM) voltage, and it will take longer to recharge. In this case, the SENSE terminals should be connected to the battery for accurate charging.

2. BATTERY VOLTAGE IS TOO HIGH

- First check the operating conditions to account for temperature compensation (a 15°C / 59°F temperature will increase PWM regulation by 0.3V for a 12V battery) and automatic equalizations.

- Check that the proper battery type has been selected.
- Disconnect the solar array, and remove the battery wire from the ProStar battery positive (+) terminal. Wait a few seconds and reconnect the battery positive terminal (leaving the solar array disconnected). After start-up, the green CHARGING LED should not be on. Measure the voltage at the SOLAR terminals (with the array still disconnected). If battery voltage is measured at the SOLAR terminals and the green LED is on, the controller may be defective.

CAUTION: If your ProStar is a positive ground version, references above to Battery (+) terminals should be Battery (-) negative terminals.

3. LOAD IS NOT OPERATING PROPERLY

- Check that the load is connected and turned on. Confirm that no fuses or circuit breakers in the system are tripped (there are no fuses or circuit breakers inside the ProStar).
- Check all connections to the load, and battery connections. Make sure voltage drops in the system are not too high (a voltage drop to the load will reduce the voltage at the load).
- Check the LED indications on the ProStar. If the red status LED is on, the load has been disconnected due to low battery voltage (LVD). This is a normal protection function of the ProStar, and the load will be automatically reconnected when the battery is charged by the solar array.
- If the LEDs are blinking, the load may have been disconnected for protection from one of the following faults:
 - short circuit or overload (R/G–Y sequencing)

NOTE: After 3 automatic retries, the fault must be cleared and the load must be switched off or disconnected for 10 seconds or longer to restore power to the load terminals

- high temperature (R–Y sequencing)
- high voltage (R–G sequencing)
- Measure the voltage at the BATTERY terminals. If above LVD and no faults are present, the load should have power. Then measure the voltage at the LOAD terminals, and if there is no voltage present the controller may be defective.

NOTE: For more technical and testing information, visit Morningstar's Website: www.morningstarcorp.com

10.0 TECHNICAL SPECIFICATIONS

Note: Values are for 12V versions. 24V versions are 2 times (48V are 4 times) the 12V values unless noted otherwise.

- Accuracy

12V	40 mV
24V	60 mV
48V	80 mV
- Min. voltage to operate

12/24V	8 V
48 V	15 V
- Self-consumption

12/24V	22 / 25 mA
48V	28 mA
- LVD current coefficient

-20 mV/amp load	
24 V / 48 V	-40 mV / -80 mV
- High temp shutdown

70°C disconnect solar	
80°C disconnect load	
60°C reconnect load	
50°C reconnect solar	
- Voltage drops (max.)

solar / battery	0.2 V
battery / load	0.12 V
- Operating life

15 years	
----------	--
- Transient surge protect

pulse power rating	1500 watts
response	< 5 nanosec

METER DISPLAY

- Type LCD
- Temp rating -30 to +85°C
- Voltage accuracy 0.5%
- Current accuracy 2.0%
- Self-consumption 1 mA

BATTERY STATUS LEDS

	Falling V	Rising V	
G to Y	12.1	13.1	Y to G
Y to Blink R	11.7	12.6	Blink R to Y
Blink R to R	11.4	12.6	R to Y

BATTERY SETPOINTS (@ 25°C)

	Gel	Sealed	Flooded
• LVD	11.4	11.4	11.4
• LVD reconnect	12.6	12.6	12.6
• PWM regulation	14.0	14.15	14.4
• Float	13.7	13.7	13.7
• Equalization	N/A	14.35	14.9 / 15.1
• HVD (solar)	15.2	15.2	15.2
• HVD (load)	15.3	15.3	15.3

BATTERY CHARGING

- Charge algorithm PWM, constant voltage
- Temp comp. coefficient -5mV/°C/cell (25°C ref)
- Temp comp. range -30°C to +80°C
- Temp comp. setpoints PWM, float, equalize, HVD
- Equalization see section 8.3

MECHANICAL

- Dimensions: (inch) 6.01 x 4.14 x 2.17
153 x 105 x 55
- Weight 12 oz (0.34 kg)
- Wire terminals Euro-style

solid	#6 AWG / 16 mm ²
multistrand	#6 AWG / 16 mm ²
fine strand	#8 AWG / 10 mm ²
- Terminal diameter 0.210 in / 5.4 mm
- Torque terminals up to 35 in-lb

ENVIRONMENTAL

- Ambient temperature -40 to +60°C
- Storage temperature -55 to +85°C
- Humidity 100% (NC)

*Specifications subject to change without notice.
Designed in the U.S.A.
Assembled in Singapore.*



MS-ZMAN-PS02 (May 2013)