

MEGALUX ENVIRO



480 lumens; over 260 lux at 1 metre



Low profile surface mount and recessed options



Waterproof to IP66



PIR option available



E-type approved



(surface mount)

TECHNICAL SPECS OVERLEAF
JUNE 2016



DESIGNED FOR MULTI-SECTOR APPLICATIONS



MEGALUX ENVIRO

Long life, high intensity Cree LEDs - High output technology produces a clean white light and creates a safe working environment, providing 480 lumens and over 260 lux at 1 metre.

Low profile designs - At just 14mm deep for the surface mount version and only 3mm for the recessed unit, these lights can be fitted in a multitude of applications.

Waterproof to IP66 - The Megalux Enviro is suitable for installation in a variety of environments, including refrigerated vehicles.

Built in PIR sensor/switch option - The electronics used within the PIR sensor/switch version have been designed to detect the movement of body heat to activate the sensor. Once the sensor has been triggered, the unit will switch on for 5 minutes before automatically switching off, preventing any unnecessary load, thereby extending battery life. If continuous movement is detected then the lights in the vehicle will remain on.

MEGALUX RECESSED (PD2)

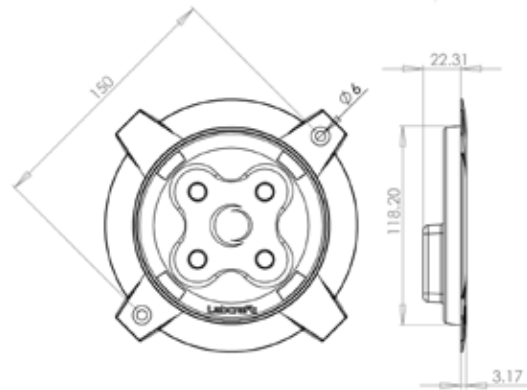

MEGALUX (PD1)

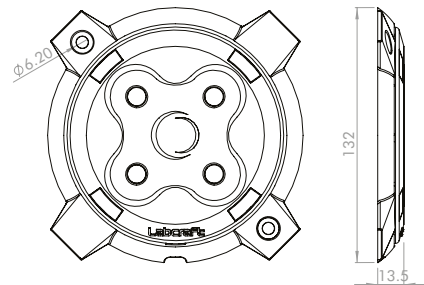

SPECIFICATION

ALL DIMENSIONS HAVE A TOLERANCE OF +/-1mm

		PD_4-1EMV (12V)	PD_4-1EPIR (12V)	PD_4-1EMV (24V)	PD_4-1/2EPIR (24V)
Voltage Range	VDC	10-32	10-15	10-32	20-32
Average Current	A	0.39	0.64	0.2	0.34
Light Output	lm	480	480	480	480
Watts	W	4W	4W	4W	4W
Weight	kg	0.15	0.15	0.15	0.15
Temp. Range	°C	-30 to +40	-30 to +40	-30 to +40	-30 to +40
IP Rating	IP	IP66	IP66	IP66	IP66

E & OE

